

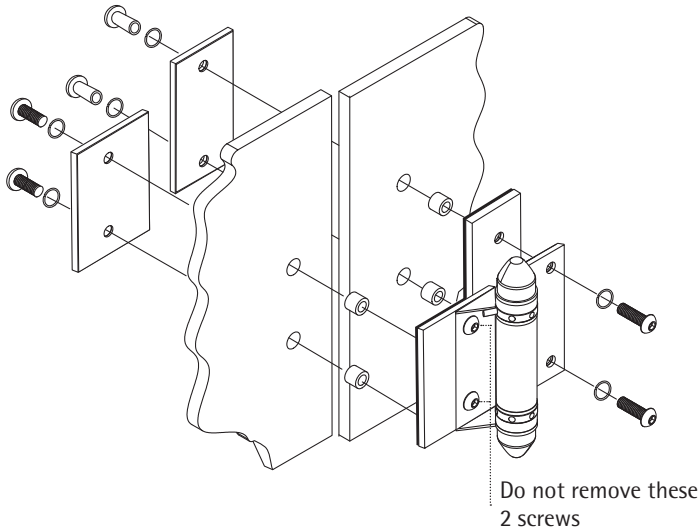

THE ARCHITECTS CHOICE

thearchitectschoice.com.au

Hinge Installation



Glass to Glass

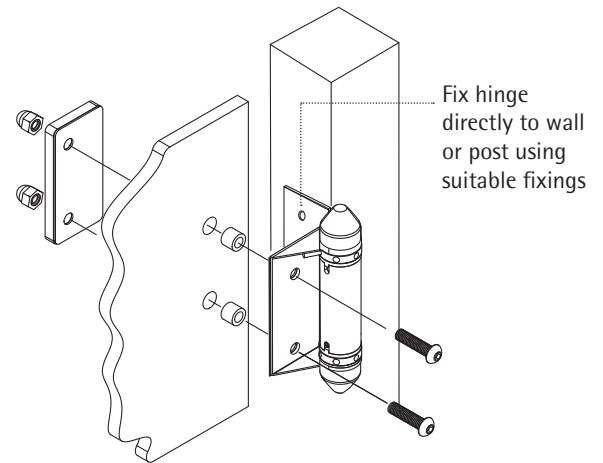

Glass to Wall/Post

Glass to Glass Hinges:

1. Remove the backing plate.
2. Line up the pre-drilled holes on the glass with those on the hinge.
NOTE: Gate must open outwards to meet compliance requirements, left and right opening directions can be achieved by turning the hinges upside down.
3. Secure the backing plate to the glass using the bolts provided. Ensure the bolts are inserted through the nylon sleeves provided.
4. Tighten bolts until the hinge is securely fastened to the panels.

DO NOT USE POWER TOOLS TO TIGHTEN SCREWS AS OVER TIGHTENING MAY SHATTER GLASS.

Wall/Post to Glass Hinges

Fix hinge to glass gate as Steps 1-4 above, then:

5. Using chocks align gate at correct height to fence and wall/post, mark the hinge hole centres on the wall/post.
6. Fix the hinge to the wall or post, ensuring gate is level and at the correct height

All Hinges once fitted

1. Adjust the tension and closing speed of the gate by moving the pin provided to the appropriate hole.
2. Check that gate self closes and latch engages from both fully open and ajar.

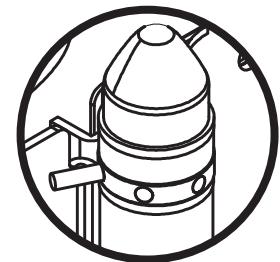

Pool Safety Requirements

Before installing a fence, check with your local Council regarding specific pool fence requirements.

For further information visit: thearchitectschoice.com.au

Proud Partners



Protector Premium is an ISO 9001 certified company





THE ARCHITECTS CHOICE

Warranty Information

Limited Manufacturer's Warranty for Protector Premium Stainless Steel and Aluminium.

Our Goods come with guarantees that cannot be excluded under the Australian Consumer Law. You are entitled to a replacement or refund for a major failure and for compensation for any other reasonably foreseeable loss or damage. You are also entitled to have the goods repaired or replaced if the goods fail to be of acceptable quality and the failure does not amount to a major failure.

The Warranty

The Supplier warrants that the Product is free from defects in workmanship and materials for the Warranty Period.

What the Supplier must do if the Product is Defective

Subject to the conditions of warranty set out in clause 3, if the Product is found to be defective and is returned to the place of purchase at the purchaser's expense during the Warranty Period, the Supplier will repair or replace the Product free of charge.

What the Purchaser must do to Claim Under the Warranty

In order to claim under the Warranty, the purchaser must:

- 3.1 Be able to show that the damage or defect has arisen solely from faulty materials or manufacture;
- 3.2 Be able to show that the Product has not been misused, mistreated, damaged or neglected by physical means including but not limited to fair wear and tear, accidents or act of God after purchase;
- 3.3 Be able to show that it has fulfilled its Product Maintenance Obligations;
- 3.4 Be able to show that the Product has not been used in a manner inconsistent with the Prescribed Purpose;
- 3.5 Be able to show that the Product has not at any time been:
 - a. attached to; nor
 - b. fixed to; nor
 - c. installed such that it is touching;Any other metallic objects or materials which are not steel;
- 3.6 Be able to show that the Product was inspected and accepted within forty eight (48) hours of the purchase;
- 3.7 Be able to show that harsh abrasives including but not limited to hydrochloric acid have never come into contact with the Product;
- 3.8 Be able to show that It was the original purchaser by production of the original receipt of purchase clearly showing the Date of Purchase;
- 3.9 Pay all transportation charges incurred in returning defective Product (or parts thereof) for repair, together with the cost of returning them to the purchaser.

Other Important Information in Relation to the Warranty

- 4.1 The Liability of the Supplier pursuant to this Warranty is (to the extent it is lawful to do so) limited to the cost of repair or replacement of the Product. The Supplier shall not in any circumstances be liable for physical or financial injury, loss or damage or for consequential loss or damage of any kind arising from the Product or its use or application by the purchaser.
- 4.2 This Warranty is non-transferable and does not apply to any purchaser who bought the product from a reseller or distributor not authorised by the Supplier, including but not limited to purchases from internet auction sites.
- 4.3 Should the Product prove to be irreparable, the Supplier reserves the right to substitute an equivalent product if available or to retract the Warranty if no replacement is available.
- 4.4 The benefits provided to the purchaser by the Warranty are in addition to other rights and remedies available to the purchaser

Who is Giving the Warranty?

The entity giving the Warranty is:

Protector Premium
ACN 619 190 797
2a Page Street
Kunda Park QLD 4556
Phone: 03 8595 3713
Email: sales@protectorpremium.com.au

Definitions

"the Date of Purchase" means the date the Product is purchased as evidenced by the properly dated receipt issued to the purchaser at the time of purchase.

"Product Maintenance Obligations" means washing down the Product with clean fresh warm water containing a mild detergent (non-acidic and non alkaline). Rinse well with fresh water removing any detergent residue paying particular attention to any areas that could retain residue. Care should be taken to avoid excessive amounts of water remaining in contact with your stainless steel. Abrasive materials or strong detergents must never be used to clean your stainless steel.

"The Product" means stainless steel or aluminium products including but not limited to fencing and balustrade systems.

"the Supplier" means Everton Australia Pty Ltd Trading as Protector Premium

"the Warranty Period" means twelve (12) months from the Date of Purchase;

"the Prescribed Purpose" means for use solely and exclusively for the intended purpose as outlined in the products installation instructions.